

MIAMI BEACH

COMMITTEE MEMORANDUM

TO: Public Safety and Neighborhood Quality of Life Committee Members

FROM: Rickelle Williams, Interim City Manager

DATE: April 17, 2024

SUBJECT: **DISCUSS AND TAKE ACTION ON OUTFRONT MEDIA GROUP CONTRACT.**

HISTORY:

On September 2, 2021, the Mayor and City Commission (“City Commission”) adopted Resolution No. 2021-31853 authorizing the City of Miami Beach (“City”) to enter into a revenue-sharing agreement (“Agreement”) with Outfront Media Group LLC (“Outfront”) for the design, construction, operation, and maintenance of bus shelters and other street furniture at designated locations within the City. The goal of the bus shelter program is to install a new bus shelter at all existing bus stop locations (currently over 200) in the City.

Design approval was obtained from the Historic Preservation Board on September 13, 2022 and from the Design Review Board on November 1, 2022. Attachment A includes a rendering of the approved design of a new “standard” bus shelter. It is worth noting that Outfront has designed three (3) variations of the new bus shelter based on size and amenities (standard, enhanced, and minimal). Furthermore, every bus shelter is anticipated to be equipped with digital “next bus” estimated time of arrival signs, either incorporated as part of the new bus shelter structure or as a stand-alone sign.

ANALYSIS

Pursuant to the Agreement, Outfront shall install a prototype bus shelter for City approval prior to commencing mass production and installation throughout the City. As such, Outfront is in the process of manufacturing the prototype bus shelter, which is proposed to be installed on the west side of Washington Avenue north of Lincoln Road (adjacent to Soundscape Park) in October 2024. The installation of the new bus shelters is anticipated to commence in early 2025 upon approval of the prototype. A phasing plan has been developed in order to ensure a smooth transition between the installation of new bus shelters and the removal of existing bus shelters. The phasing plan is as follows:

- Priority 1: Installation of enhanced shelters at locations with high ridership;
- Priority 2: Installation of new shelters at locations without shelters and more than 50 boardings per day;
- Priority 3: Installation of new shelters at locations without shelters and fewer than 50 boardings per day;

- Priority 4: Installation of minimal shelters pending evaluation due to low ridership and single-family land use; and
- Priority 5: Replacement of the remaining old shelters with new shelters.

Pursuant to the Agreement, Outfront anticipates completing the installation of approximately 200 bus shelters citywide by November 2026.

CONCLUSION:

The outlined schedule for mass production and installation of new bus shelters provides a clear roadmap for the timely completion of this project. As we move forward, the Administration remains committed to continue collaborating closely with Outfront, to expedite the timeline and ensure a smooth and successful execution of this project.

Applicable Area

Citywide

Is this a "Residents Right to Know" item, pursuant to City Code Section 2-14?

Yes

Does this item utilize G.O. Bond Funds?

No

Strategic Connection

Mobility - Increase multi-modal mobility citywide and connectivity regionally.

ATTACHMENTS:

Description	Type
☐ Attachment A - Rendering of New Standard Bus Shelter	Other
☐ Attachment B - Referral Item R9 V - December 13, 2023	Memo

Attachment A - Rendering of New "Standard" Bus Shelter

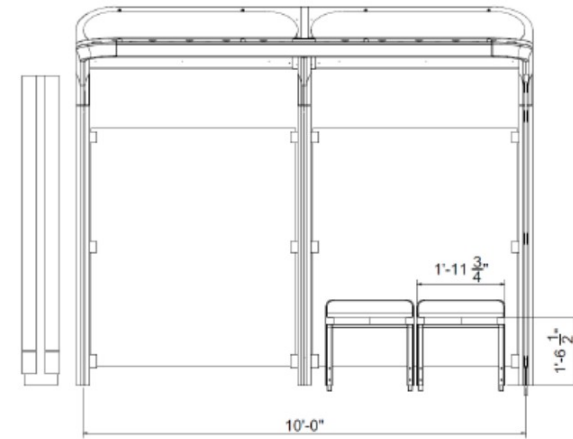
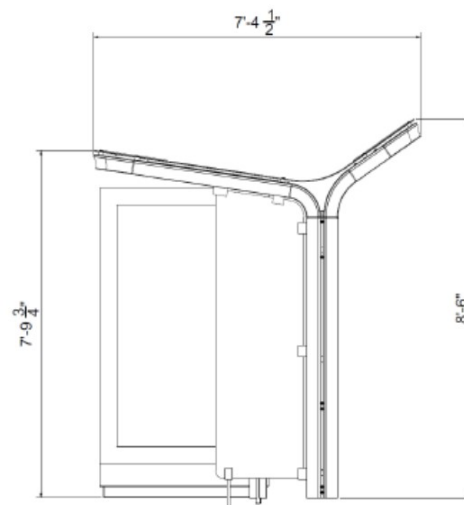

MIAMI BEACH

COMMISSION MEMORANDUM

TO: Honorable Mayor and Members of the City Commission
FROM: Commissioner Kristen Rosen Gonzalez
DATE: December 13, 2023

SUBJECT: DISCUSS/TAKE ACTION ON OUTFRONT MEDIA GROUP CONTRACT.

BACKGROUND/HISTORY

Discussion regarding the City's contract for bus shelters with Outfront Media Group, and a referral to the Finance and Economic Resiliency Committee, to discuss the status of same, including possible termination.

SUPPORTING SURVEY DATA

N/A

FINANCIAL INFORMATION

N/A

Applicable Area

Citywide

Is this a "Residents Right to Know" item, pursuant to City Code Section 2-14?

Yes

Does this item utilize G.O. Bond Funds?

No

Strategic Connection

Non-Applicable

Legislative Tracking

Commissioner Kristen Rosen Gonzalez

December 13, 2023
City of Miami Beach Hybrid Commission Meeting

Miami Beach.

Dr. Rosenfeld responded that the total would be \$450,000.

Mayor Meiner added that this program is a great enhancement to recruit and keep families in Miami Beach.

Voice vote: 7-0.

5:11:15 p.m.

R9 V DISCUSS/TAKE ACTION ON OUTFRONT MEDIA GROUP CONTRACT.

Vice-Mayor Kristen Rosen Gonzalez
Addendum added on 12/11/2023.

ACTION: Discussion held. Vice-Mayor Rosen Gonzalez made a motion to refer the Item; seconded by Commissioner Bhatt. The Item was referred to the Public Safety Neighborhood and Quality of Life Committee. Vote: 7-0. **Mark Taxis to place on the Committee Agenda. Jose Gonzalez to handle.**

Vice-Mayor Rosen Gonzalez stated that Commissioner Bhatt's Item about the Kiosks inspired her to add this Item to the agenda. The City signed a contract with Outfront Media Group for the bus shelters two years ago and no improvements have been made. She would like to have the discussion referred to the Public Safety Neighborhood and Quality of Life Committee to have a conversation about where the process stands and when the City should be expecting the new bus shelters. The City's bus shelters are completely outdated, we should have shelters that say when the buses are arriving. With the referral, Outfront Media Group can explain why not much has been done since the contract was signed two years ago. The residents deserve this.

Mayor Meiner added that further discussion will be held during the Public Safety Neighborhood and Quality of Life Committee.

The Item was referred to the Public Safety, Neighborhoods, and Quality of Life Committee by unanimous consent.

2:31:48 p.m.

R9 W DISCUSS/TAKE ACTION REGARDING THE TERMINATION OF THE AGREEMENT WITH IKE SMART CITY FOR DIGITAL MEDIA KIOSKS.

Commissioner Tanya K. Bhatt
Addendum added on 12/11/2023.

AFTER-THE-FACT RESOLUTION:

A RESOLUTION OF THE MAYOR AND CITY COMMISSION OF THE CITY OF MIAMI BEACH, FLORIDA, AUTHORIZING THE CITY MANAGER TO NEGOTIATE AND EXECUTE AN AMENDMENT TO THE AGREEMENT BETWEEN THE CITY AND IKE SMART CITY, LLC (IKE), PURSUANT TO REQUEST FOR PROPOSALS (RFP) NO. 2022-040-KB, TO DESIGN, MANUFACTURE, INSTALL, MAINTAIN, AND OPERATE INTERACTIVE DIGITAL MEDIA KIOSKS; SAID AMENDMENT (1) GRANTING THE CITY, FOR ITS CONVENIENCE, THE